

REVISION			
Rev.	Description	Date	Approval
-	-	-	-

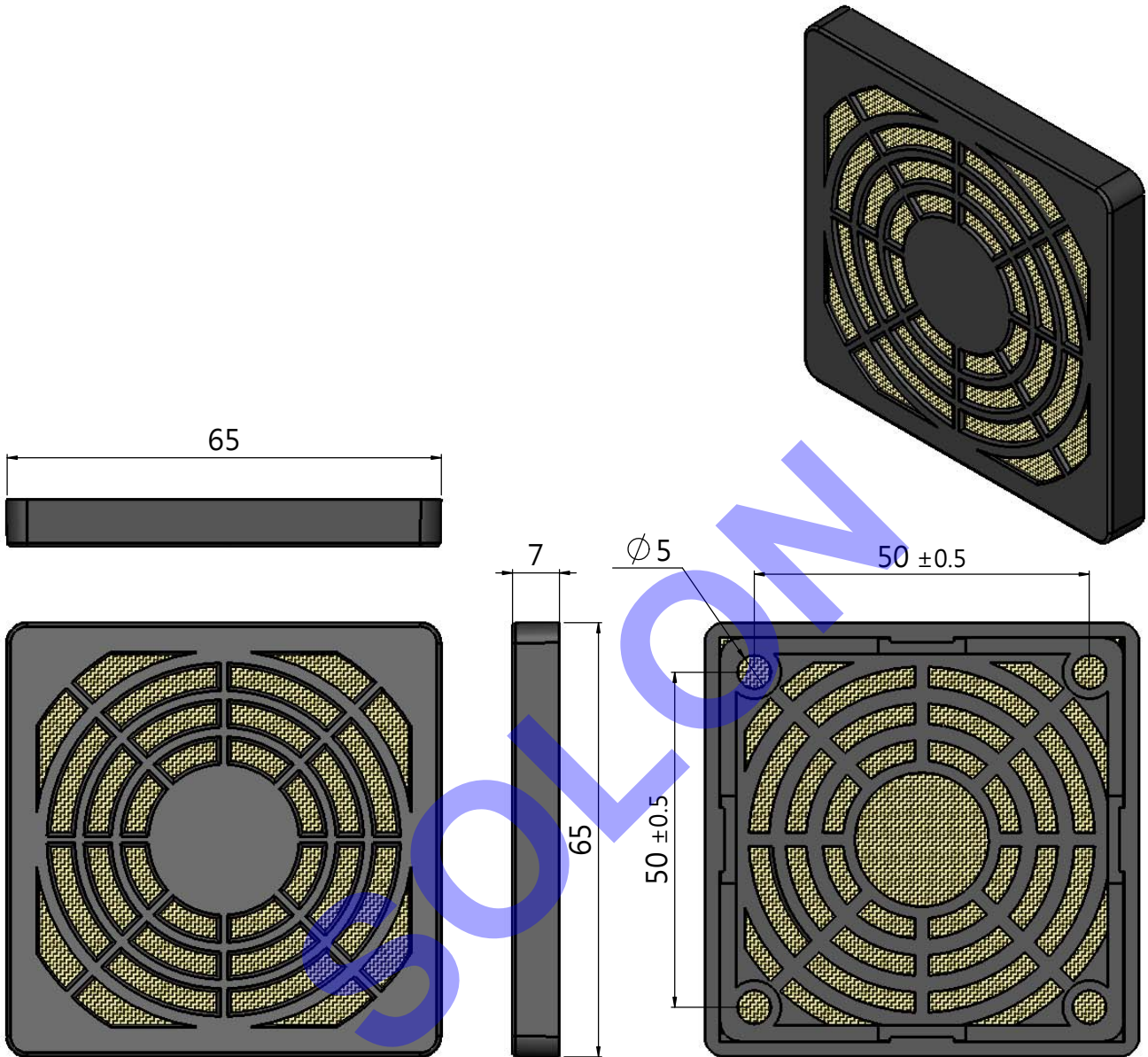

洋健企業  
 2022.03.03  
 工程部  
 批准  
 2022.03.03  
 洋健企業

- Notes:
- Material: Cover-ABS Resin, UL94-HB  
Bottom-ABS Resin, UL94-HB  
Filter-Polyurethane foam 泡棉
  - Color: Black 黑色
  - Unless otherwise specified:  
The tolerance is listed as follows:  
X.X - ±0.10mm  
X.XX - ±0.05mm
  - Weight: 35 g

		DIMENSIONS ARE IN MILLIMETER		NAME	DATE	Model NO. FA-60	
		TOLERANCES:		DRAWN	Neafa	2013/6/21	
		FRACTIONAL ±		CHECKED			
		ANGULAR: MACH ± BEND ±		ENG APPR.			Card NO. HC-823
		TWO PLACE DECIMAL ±		MFG APPR.			PART NO. AB-6023-0
		THREE PLACE DECIMAL ±		Q.A.			PART NAME
		MATERIAL		<b>SOLON</b>			
		FINISH					
NEXT ASSY		USED ON		SIZE A		DWG. NO. AB-6023-0-0	
APPLICATION		DO NOT SCALE DRAWING		SCALE:1:5		WEIGHT:	
						REV. 0	
						SHEET 1 OF 1	

**PROPRIETARY AND CONFIDENTIAL**  
 THE INFORMATION CONTAINED IN THIS DRAWING IS THE SOLE PROPERTY OF SOLON ENTERPRISE CO., LTD. ANY REPRODUCTION IN PART OR AS A WHOLE WITHOUT THE WRITTEN PERMISSION OF SOLON ENTERPRISE CO., LTD. IS PROHIBITED.